

GARDENLINE®

Double Glider

User Guide



Now you have purchased a Gardenline® product you can rest assured in the knowledge that as well as your 2 year parts and labour guarantee you have the added peace of mind of dedicated helplines and web support.

AFTER SALES SUPPORT

☎ 1866 632 1718

MODEL: VTS-SB1304, 04/14

CONTENTS

2 Introduction

3 Parts List

4-5 Assembly

6 General Safety & Guidelines

7 2-Year Limited Warranty

INTRODUCTION

Congratulations!

You have made an excellent choice with the purchase of this quality Gardenline® product















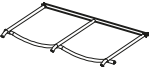

By doing so you now have the assurance and peace of mind which comes from purchase a product that has been manufactured to the highest standards of performance and safety, supported by the high quality standards of ALDI.

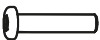
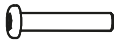
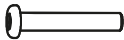
We want you to be completely satisfied with your purchase so this Gardenline® product is backed by a comprehensive manufacturer's 2 year warranty and an outstanding after sales service through our dedicated Helpline.

We hope you will enjoy using your purchase for many years to come.

If you require technical support or in the unlikely event that your purchase is faulty please telephone our Helpline for immediate assistance. faulty product claims made within the 2 year warranty period will be repaired or replaced free of charge provided that you have satisfactory proof of purchase (keep your receipt). This does not affect your statutory right. However, be aware that the warranty will become null and void if the product is found to have been deliberately damaged, misused or disassembled.

PARTS LIST

<p>A/2pcs</p> 	<p>B/2pcs</p> 	<p>C/2pcs</p> 	<p>D1/1pc</p> 
<p>D2/1pc</p> 	<p>E/1pc</p> 	<p>F/1pc</p> 	<p>G/2pcs</p>  M6*15
<p>H/12pcs</p>  M6*35	<p>I/4pcs</p>  M6*50	<p>J/2pcs</p>  M6*55	<p>K/2pcs</p>  M6*58
<p>L/24pcs</p> 	<p>M/14pcs</p> 	<p>N/8pcs</p> 	<p>O/14pcs</p> 
<p>P/24pcs</p> 	<p>Q/24pcs</p> 	<p>R/1pc</p> 	

ASSEMBLY

Step 1

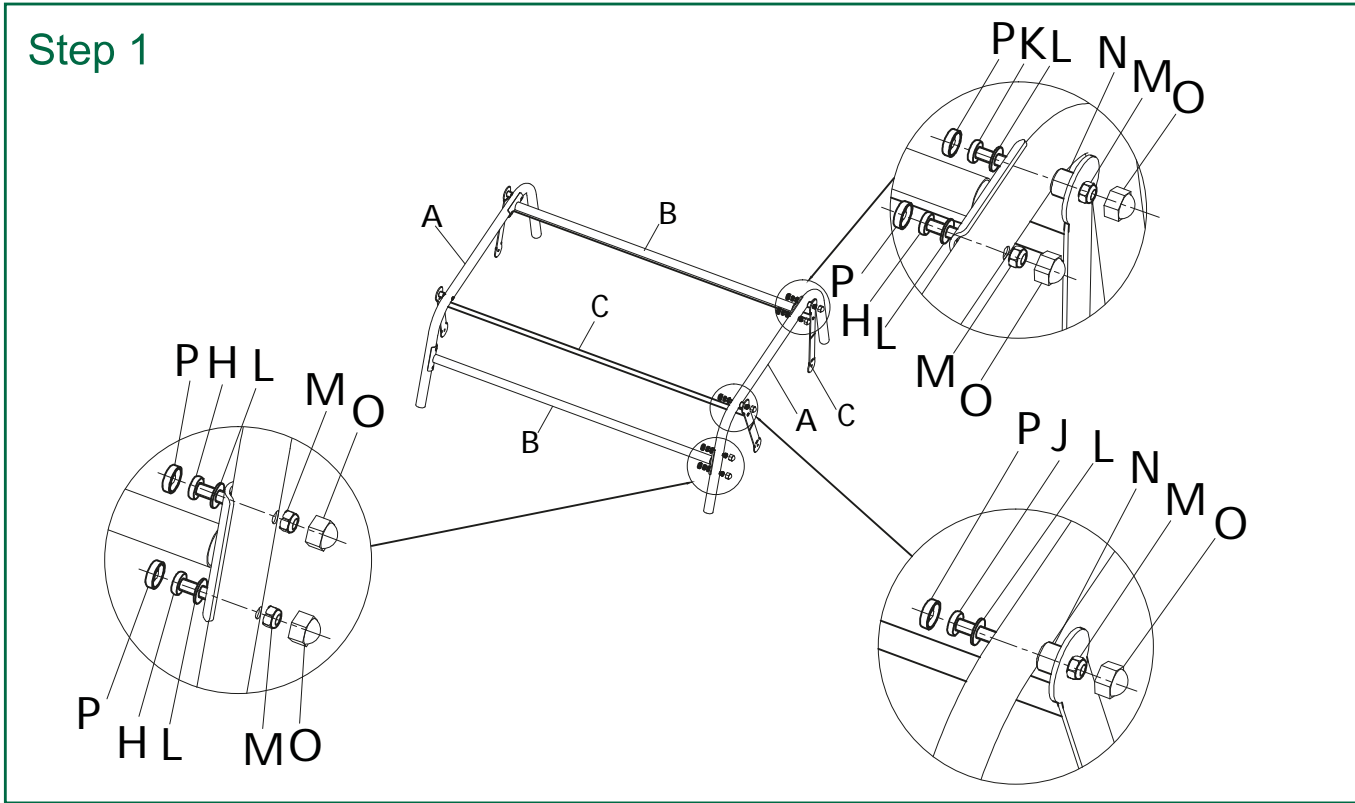

Step 2

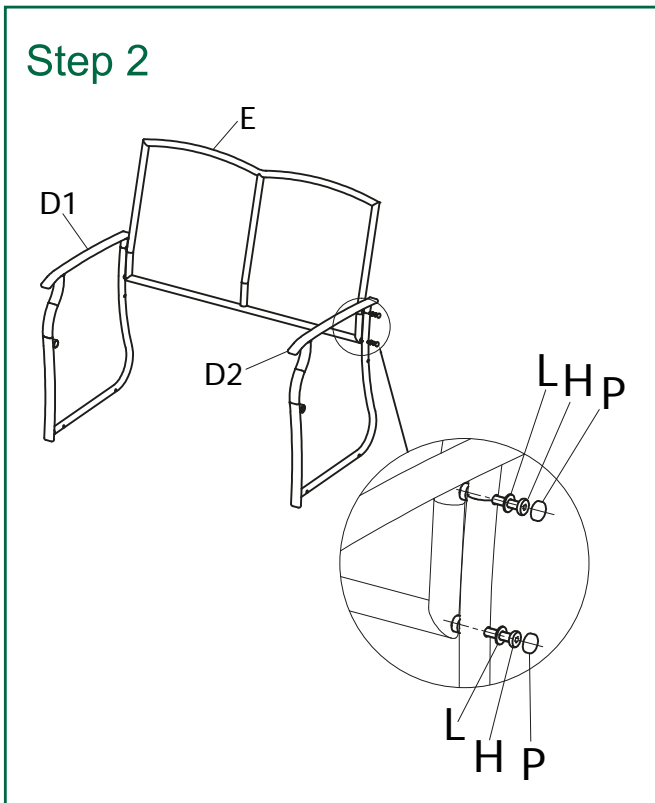

Step 3

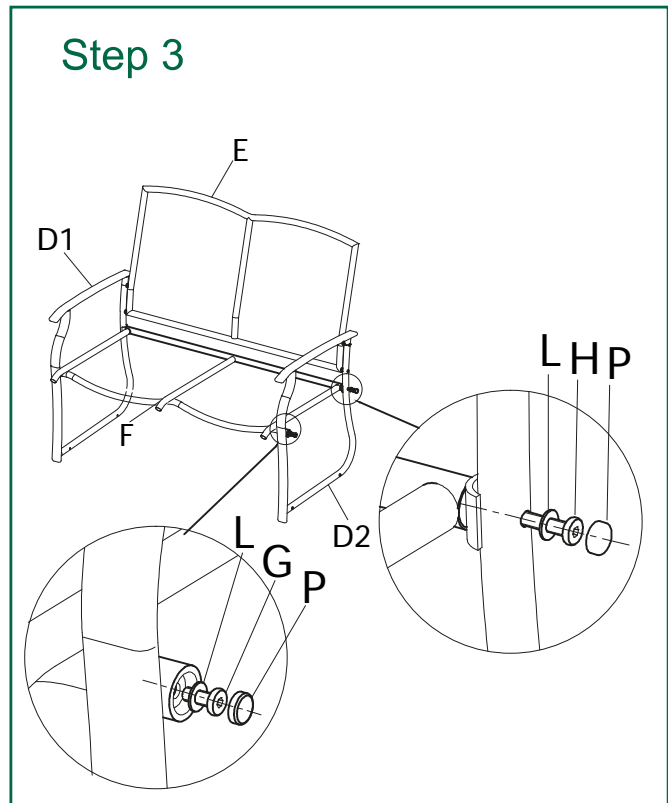

ASSEMBLY

Step 4

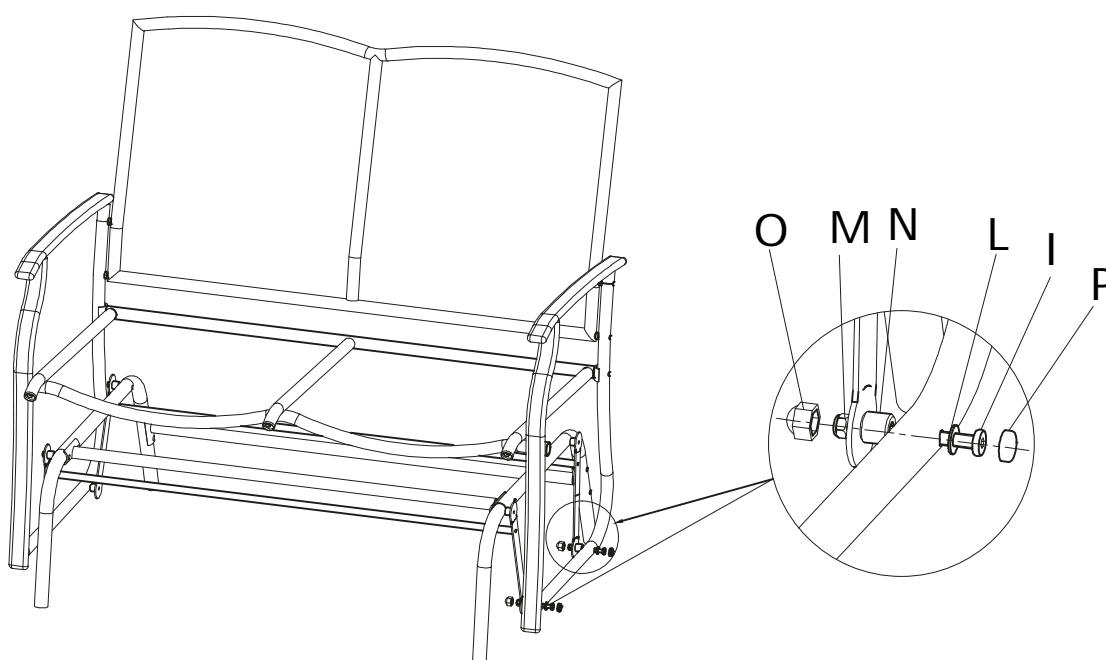

Step 5

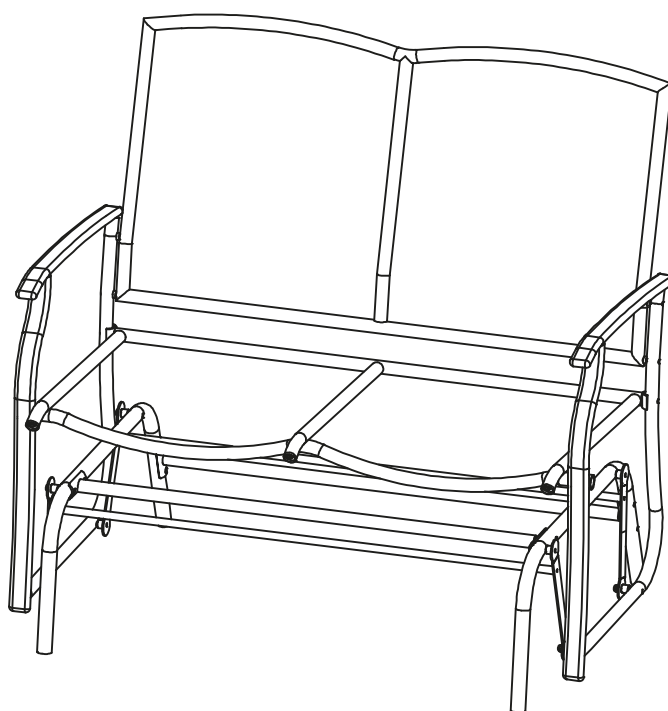

GENERAL SAFETY & GUIDELINES

IMPORTANT! PLEASE RETAIN FOR FUTURE REFERENCE: READ CAREFULLY

DANGER TO CHILDREN

- Keep all packaging and small parts away from children. Ensure that children do not place packaging over their heads or swallow any parts. There is a risk of suffocation.
- The glider comes with a number of small pieces. These can be highly dangerous if swallowed. Keep children away while assembling the product.

CAUTION Risk of injury and material damage

- Incorrect assembly causes safety risks.
- Assemble the glider on a soft and even surface; place packaging underneath to avoid damaging or scratching any part of the surface.
- Do not sit or stand on the glider as it may get damaged.
- Check all screws and connectors regularly. Loose screw connectors could result in injury.
- If injury occurs, do not continue to use the glider.
- Only use the glider for its intended purpose and do not overload it.

INTENDED USE

The glider is intended exclusively for private outdoor use and is not suitable for commercial use.

CARE NOTE

- In order to increase the longevity of this product, please clean the product regularly using a damp cloth. Never use any abrasive cleaning agents!
- Do not expose the unit to harsh weather conditions.
- It is recommended to cover the product if not in use to protect the surfaces against dirt and rain.

DISPOSAL

Packaging material

Keep packaging out of the reach of children as it may be swallowed or cause suffocation. Dispose of packaging in accordance with local authority regulations.

Product

Dispose of the product in accordance with local authority regulations. For more information, contact your local council.

2-YEAR LIMITED WARRANTY

What this warranty covers:

This Gardenline product manufactured for ALDI INC., is warranted to be free from defects in material and workmanship for a period of two years from the date of your original purchase. The Supplier will, as its option, repair or replace any original part of this product that is found to be defective under the terms of this warranty. This warranty is only valid for the original retail purchaser of this product and is not transferable. Keep the original sales receipt. Proof of purchase is required to obtain warranty performance.

What this warranty does not cover:

This warranty does not cover damage due to abuse, misuse, normal wear, excessive wear and tear caused by owners neglect, including failure to perform routine maintenance, accidents, malfunctions caused by unauthorized alterations, improper installation, use of unauthorized parts or attachments, lost parts or if used for commercial or rental purposes and acts of nature.

This Limited Warranty does not cover any consequential or incidental damages of any kind, including transportation to get warranty service, loss of time, and loss of use. Some states do not allow exclusion or limitation of incidental or consequential damages, so the above limitation may not apply to you.

The period of coverage is:

This limited warranty lasts for a period of two years from the date of your original purchase. Any implied warranty arising under state law is limited in duration to the period of this Limited Warranty. Some states do not allow limitations on how long an implied warranty lasts, so the limitations may not apply to you

Proof of Purchase

This warranty is valid for the original purchase and is not transferable. Please keep your receipt as the best proof of purchase, and as proof of date on which the purchase was made.

Extent of Warranty

This warranty is limited to defects in workmanship or parts. All defective products or parts will be repaired or replaced. This warranty does not cover batteries or any other consumable items.

Normal Wear and Tear

This warranty does not cover normal wear and tear to the products or parts.

How you can get service:

Please direct all warranty service inquiries as follows:

If in writing, mail to: Schuette & Co. Far East Ltd.

Unit 1901, Skyline Tower, 39 Wang Kwong Road, Kowloon Bay, Hong Kong

If by telephone, call 1-866-632-1718

How state Law applies:

This limited Warranty gives you specific legal rights, and you may also have other rights which vary from state to state.

DISTRIBUTED BY
ALDI INC. BATAVIA, IL 60510
www.aldi.us